



**Technical Service  
BULLETIN**

August 24, 2004

Title:

**FUEL GAUGE INACCURACY**

Models:

'04 Prius

**TSB**

**REVISÉD**  
**ELECTRICAL**  
**EL010-04**

**TSB REVISION**

**September 23, 2004: PANT Bulletin search clarified in Note in Parts Information; new Repair Procedure step 7 inserted on page 11. Previous versions of this TSB should be discarded.**

**Introduction** Some 2004 Prius customers may complain of the following:

- Fuel gauge is not accurate and/or
- Fuel tank volume is not close to the stated capacity

An updated Combination Meter Computer and Fuel Filler Pipe have been created to improve this condition.

**Applicable Vehicles**

- **2004** model year **Prius** vehicles produced **WITHIN** the VINs shown below.

APPLICABLE VEHICLE VIN RANGE	PARTS NEEDED	REPAIR PROCEDURE
JTDKB2#U#40000001 – JTDKB2#U#40057579	Meter and Filler Pipe	1 and 2
JTDKB2#U#40057580 – JTDKB2#U#40078361	Filler Pipe Only	2 Only

**Parts Information**

PREVIOUS PART NUMBER	CURRENT PART NUMBER	PART NAME	QTY
77201-47080	77201-47090	Pipe, Fuel Filler	1
83291-47100	83291-47101-RP*	Computer, Combination Meter	1

**\* NOTE:**

The combination meter computer contains the vehicle odometer memory. This component should be ordered directly from the vendor (Yazaki) with the correct mileage programmed. (Please refer to PANT Bulletin No. 01-17, "G101-17: Digital Odometer Replacement Program Launch," using Keyword search "01-17" on the Technical Information System [TIS], for additional information.)

**Warranty Information**

PROCEDURE	OP CODE	DESCRIPTION	TIME	OFF	T1	T2
1	EL4006	R & R Fuel Filler Pipe and Combination Meter Cluster	2.0	83291-47100	73	74
2	EL4007	R & R Fuel Filler Pipe	1.0	77201-47080	87	50

**Applicable Warranty\*:**

This repair is covered under the Toyota Comprehensive Warranty. This warranty is in effect for 36 months or 36,000 miles, whichever occurs first, from the vehicle's in-service date.

\* Warranty application is limited to correction of a problem based upon a customer's specific complaint.



**Repair Procedure 1:  
Combination Meter Computer**

**Replace Combination Meter Computer.**

1. Verify that the Parts Department has received the new combination meter computer with the vehicle's correct mileage.
2. Verify that the vehicle is on a level surface.
3. Remove the Combination Meter per "overhaul" instructions in the Technical Information System (TIS), 2004 model year Prius Repair Manual: *Instrument Panel/meter: Combination Meter Assy.*

**CAUTION:**

- Before performing each step of the disassembly/reassembly procedure below, eliminate static electricity by touching the vehicle body to prevent the components from being damaged.
- Upon removing the combination meter computer from the static free packaging, be sure to hold it by the edges as shown in the illustration.

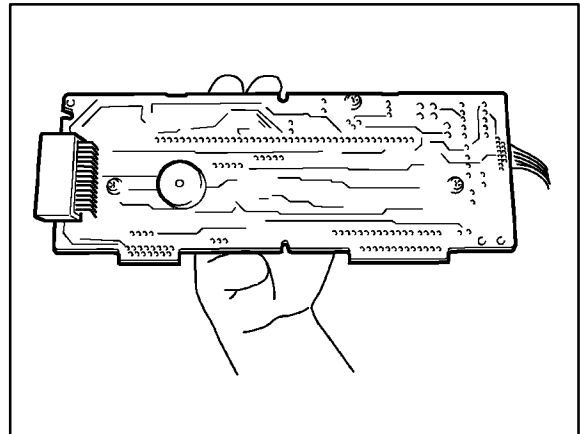

4. Remove Combination Meter Cover RH.
  - A. Remove the screw, then remove the combination meter cover RH.

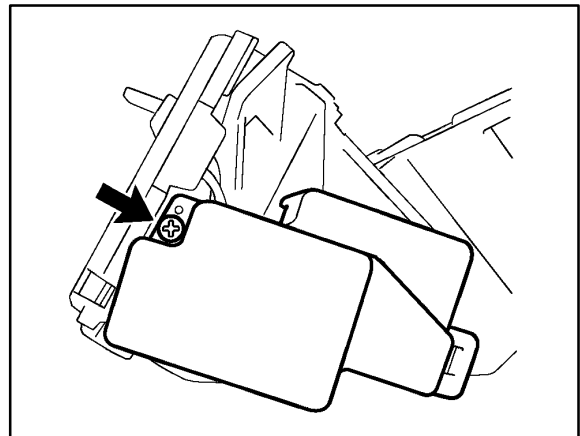

5. Remove Combination Meter Cover No. 3.
  - A. Remove the 4 screws.
  - B. Widen the 2 claws along the outside to disengage them.
  - C. Raise the cover from the bottom and remove the combination meter reflector No. 1.

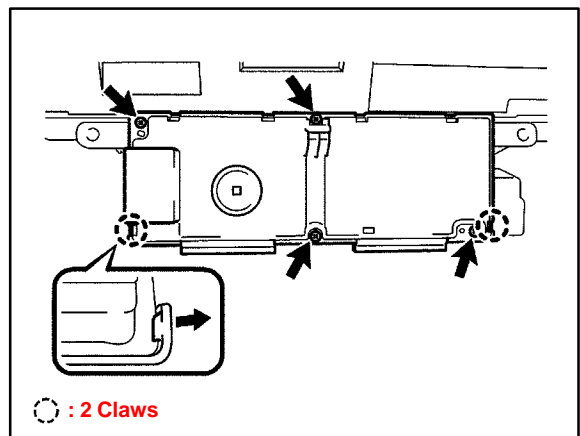

**Repair  
Procedure 1:  
Combination  
Meter  
Computer**  
(Continued)

6. Remove Meter Circuit Plate No. 3.
  - A. Pull the connector locks in the direction indicated by the arrows in the illustration, and remove the meter circuit plate No. 3.

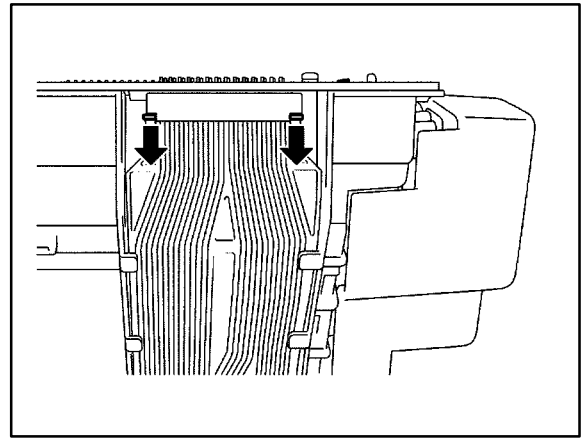

7. Remove Meter Circuit Plate No. 4.
  - A. Pull the connector locks in the direction indicated by the arrows in the illustration, and remove the meter circuit plate No. 4.

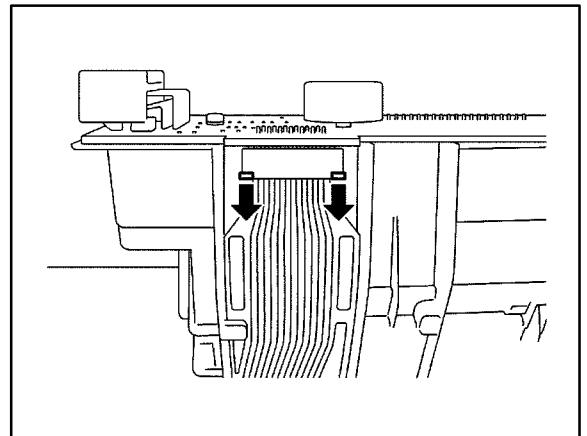

8. Remove Combination Meter Computer.
  - A. Disconnect the connector and remove the combination meter computer.

**HINT:**  
There is no locking mechanism on this connector.

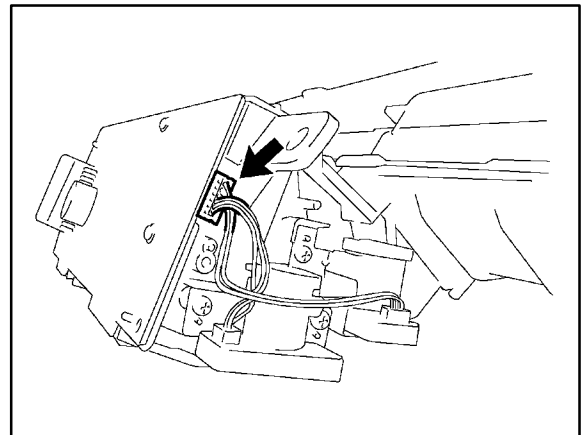

**Repair  
Procedure 1:  
Combination  
Meter  
Computer  
(Continued)**

9. Install Combination Meter Computer.
  - A. Install the new combination meter computer.
  - B. Connect the connector.

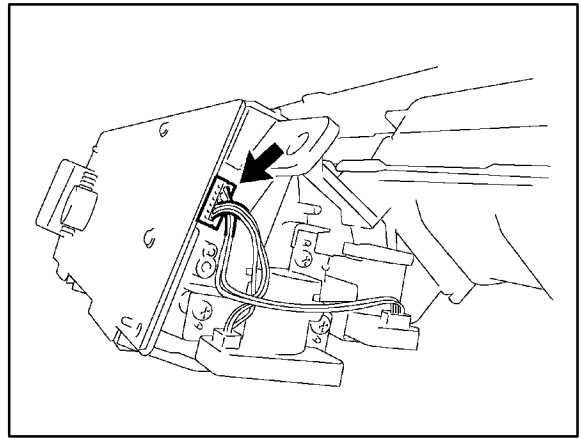

10. Install Meter Circuit Plate No. 4.
  - A. Pull the connector locks in the direction indicated by the arrows in the illustration, and install the meter circuit plate No. 4.
  - B. Lock the connector lock.

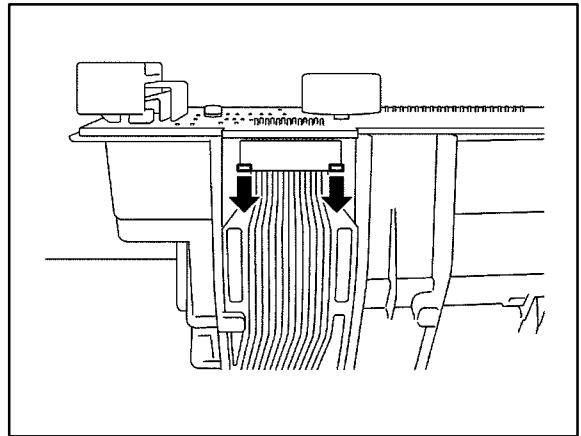

11. Install Meter Circuit Plate No. 3.
  - A. Pull the connector locks in the direction indicated by the arrows in the illustration, and install the meter circuit plate No. 3.
  - B. Lock the connector locks.

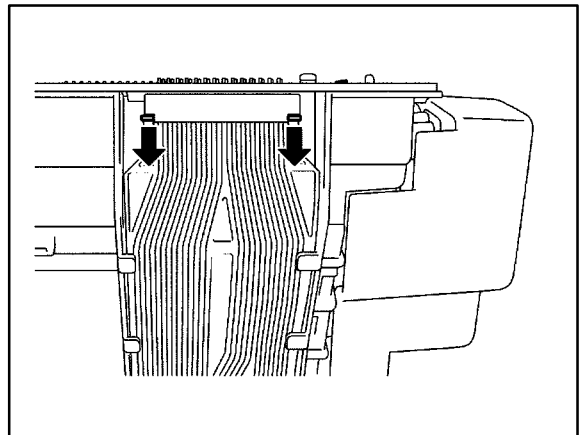

**Repair Procedure 1:  
Combination Meter Computer**  
(Continued)

12. Install Combination Meter Cover No. 3.
  - A. Install the combination meter reflector No. 1 with the 4 screws.

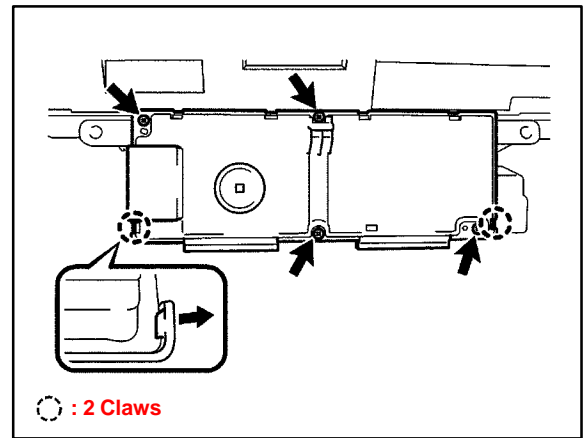

13. Install Combination Meter Cover RH.
  - A. Install the combination meter cover RH with the screw.

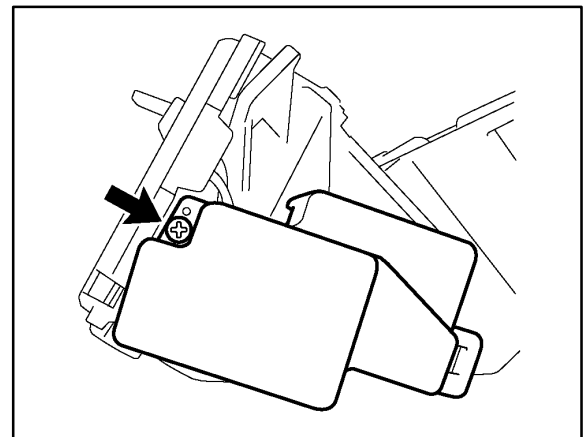

14. Install Combination Meter in Reverse of Disassembly.

15. Reset Inclination Sensor.

**HINT:**  
After replacement of the combination meter computer, reset the standard horizontal angle of the inclination sensor.

- A. Keep the vehicle stationary in both longitudinally and laterally horizontal position (within +/- 0.3°).

**HINT:**  
Place the vehicle on a level surface such as an alignment rack, if available.

- B. Switch to the "Trip A" mode of the odometer display.
- C. Turn the power switch OFF.

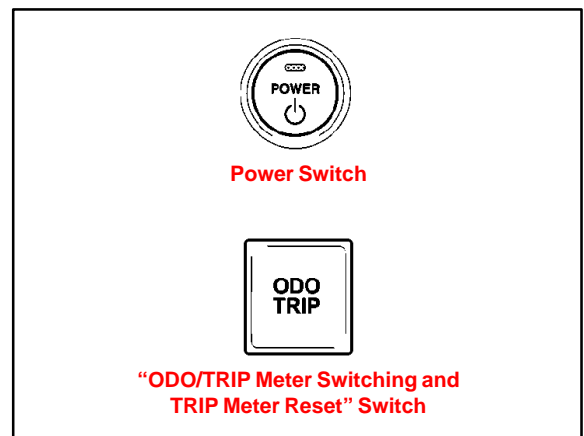

**Repair Procedure 1: Combination Meter Computer**  
(Continued)

- D. Make sure your foot is off of the brake pedal.
- E. Push in and hold the “ODO/TRIP” button.
- F. Turn the power switch ON (push the “POWER” button twice).
- G. Turn the “ODO/TRIP” button OFF, then ON 3 times within 5 seconds.
- H. Continue to hold the “ODO/TRIP” button until the “ODO” indicator in the display turns off and a 6–digit code (#####) is displayed.
- I. Release the “ODO/TRIP” button.
- J. Push and hold the “ODO/TRIP” button for 5 seconds or more again. The 6–digit code (#####) will then change to a 5–digit code (#####).
- K. After “1” is displayed at the 3rd digit of the 5–digit code, release the “ODO/TRIP” button.
- L. Approximately 5 seconds after “1” is displayed at the 3rd digit, the “TRIP A” indicators are displayed, and the odometer returns to the normal operation.

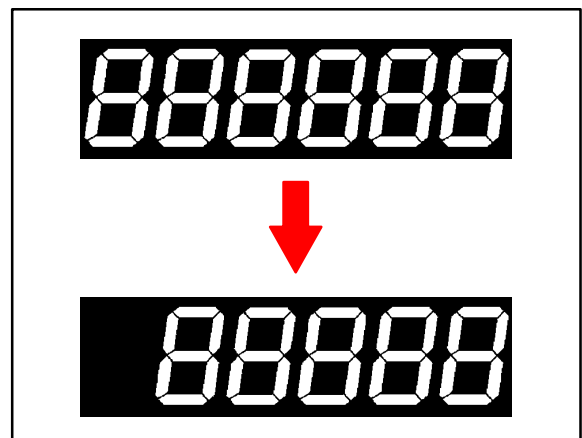

**NOTE:**

- The “TRIP A” mileage will revert to 0.0 miles in this procedure.
- Do not drive the vehicle before the reset procedure has been completed.

**HINT:**  
If a write error occurs, start the procedure again from the beginning.

X            Y            Z

**X: Values Written Into Meter (Longitudinal Direction)**  
**Y: Write Status and Result**  
**Z: Values Written Into Meter (Lateral Direction)**

**Write Status and Result:**  
**0: Writing**  
**1: Write Completed**  
**2: Write Error**  
**3: Write Canceled**

Repair  
Procedure 2:  
Fuel Filler  
Pipe

### Replace Fuel Filler Pipe.

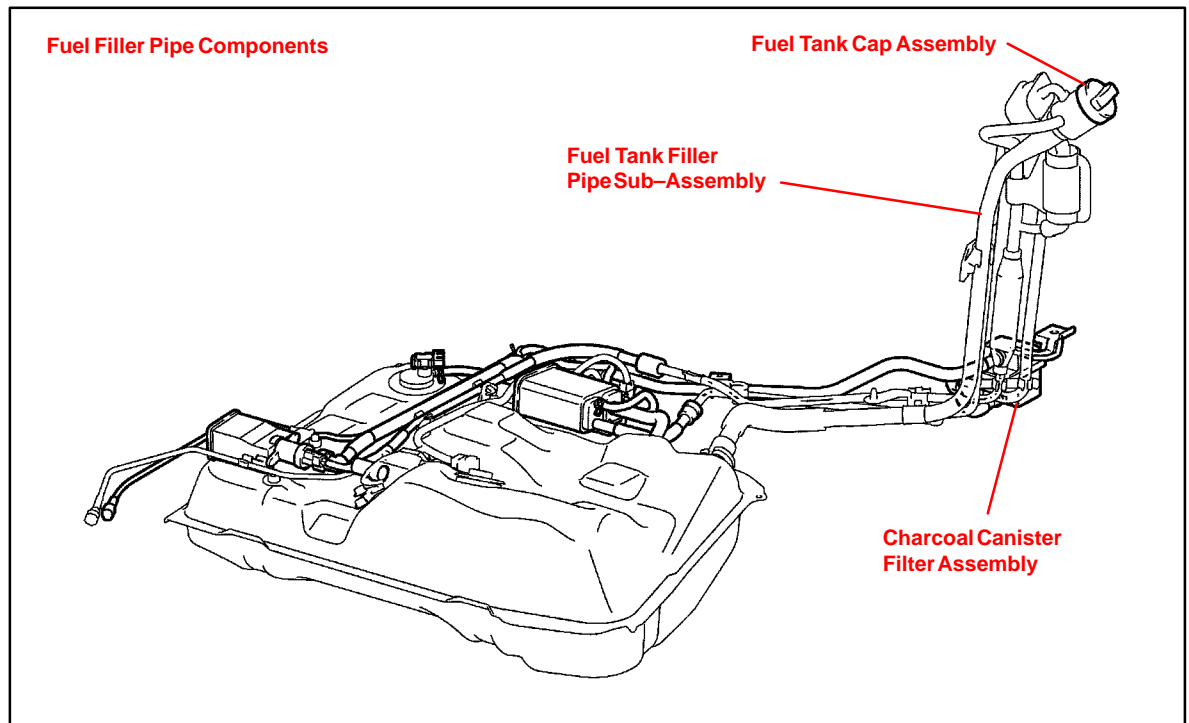

#### PRECAUTIONS:

- Verify that the fuel level is 3/4 tank or below (to prevent fuel spillage).
- Verify that there will be no flames or sparks in the area in which the procedure will take place.
- Do not smoke during this operation.

1. Disconnect Engine Wire No. 3 (battery negative terminal).
2. Remove Left Rear Tire.
3. Remove Fuel Tank Cap Assembly.
4. Remove Floor Under Cover No. 1.
  - A. Remove the 2 clips and 2 bolts, then remove the floor under cover No. 1.

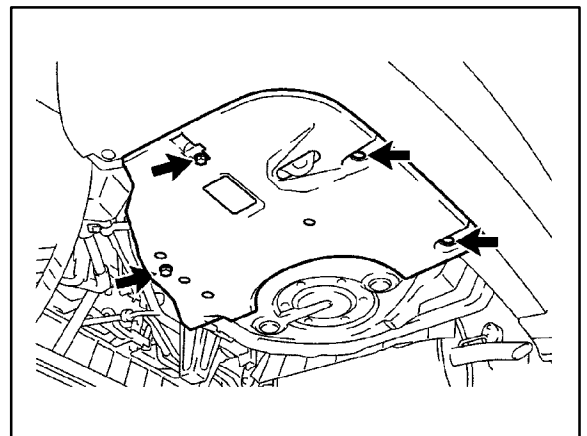

**Repair Procedure 2:  
Fuel Filler Pipe**  
(Continued)

5. Remove Fuel Tank Filler Pipe Protector.
  - A. Remove the nut, then remove the fuel tank filler pipe protector.

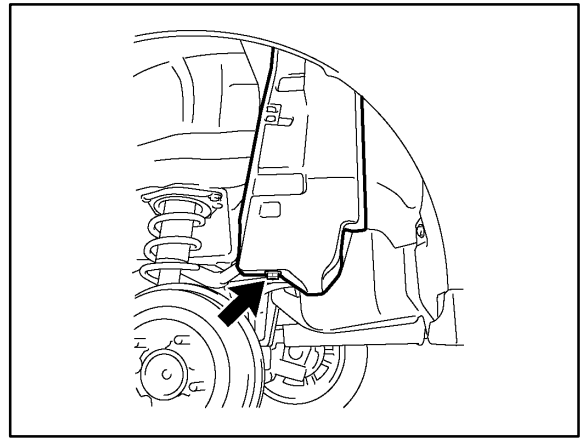

**FUEL PIPE CONNECTOR CAUTIONS:**

- Remove any dirt or foreign objects from the connectors before proceeding.
- Be careful not to scratch the O-ring on the connector or the connector may not seal properly upon reconnection.
- Disconnect the fuel pipe connector by hand. Do not use any tools.
- Do not forcibly bend, twist or turn the nylon tube.
- After disconnection, protect the connector end by covering it with a vinyl bag.
- If the connector is stuck, gently push and pull it to release.

6. Remove Fuel Tank Filler Pipe Sub-assembly.
  - A. Disconnect the fuel tank vent hose (fuel tank inlet pipe side).
    - a. Pinch the retainer and pull out the fuel tank vent connector No. 2 with the connector pushed to the pipe side.

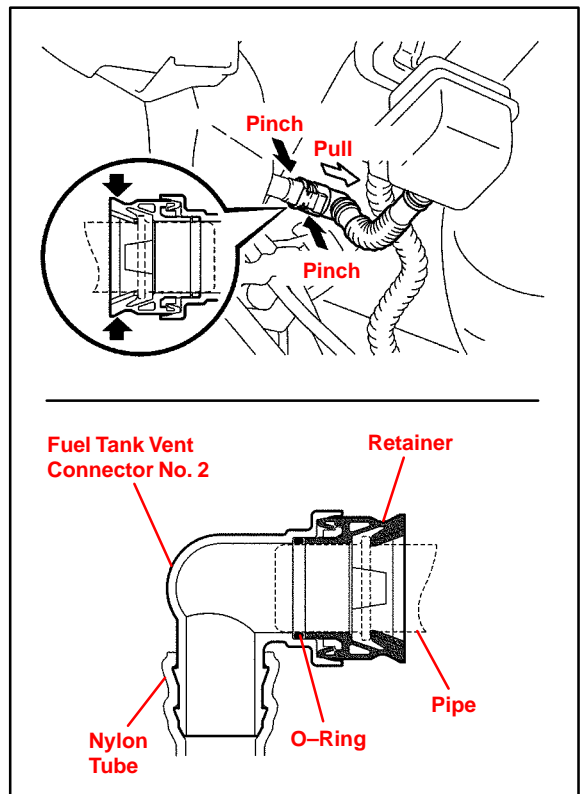

**Repair  
Procedure 2:  
Fuel Filler  
Pipe  
(Continued)**

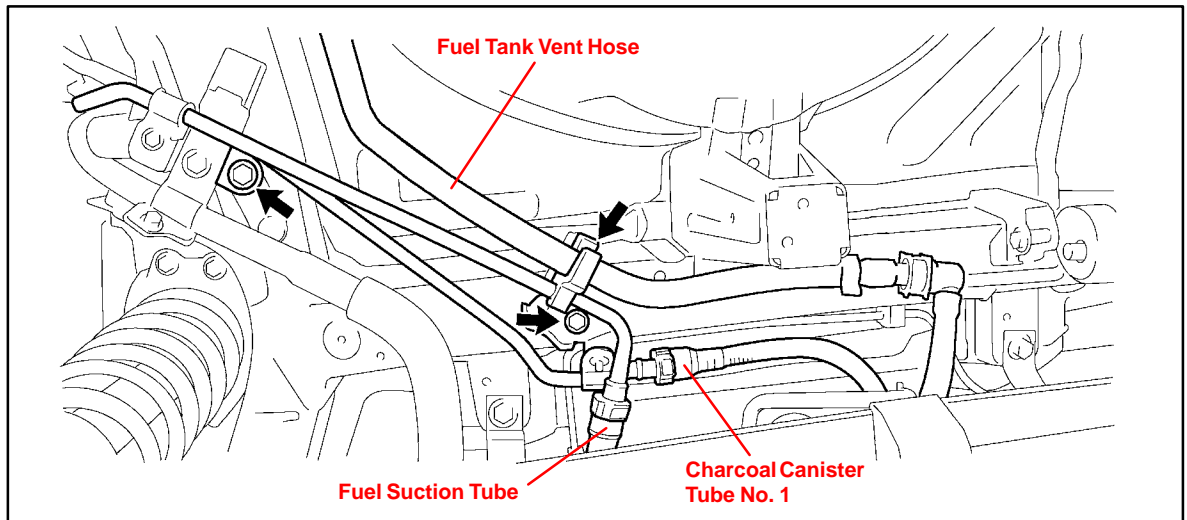

- B. Disconnect the fuel tank vent hose (fuel tank side) from the clamp.

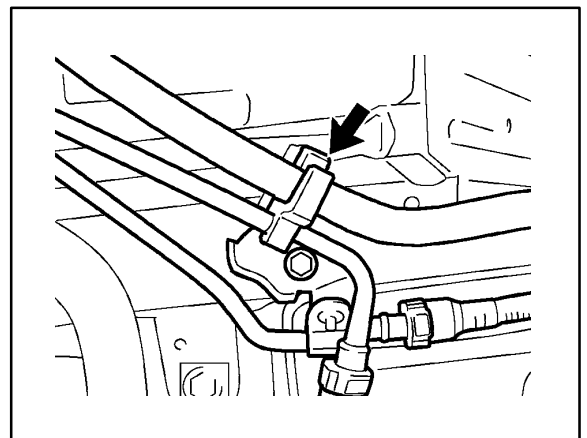

- C. Disconnect the fuel suction tube.
  - a. Pinch the retainer and pull out the quick connector with the connector pushed to the pipe side.

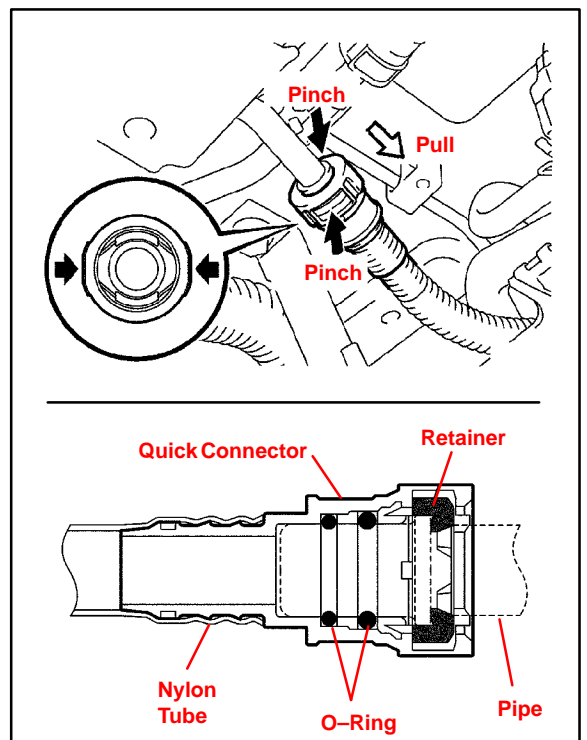

**Repair Procedure 2:  
Fuel Filler Pipe**  
(Continued)

- D. Disconnect the charcoal canister tube No. 1.
  - a. Pinch the retainer and pull out the quick connector with the connector pushed to the pipe side.

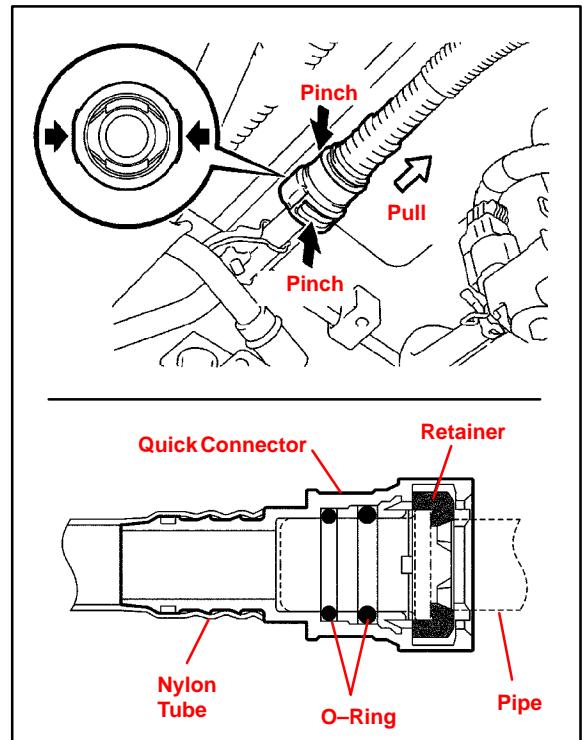

- E. Remove the fuel filler pipe clamp and fuel tube connector from the fuel tank inlet pipe.

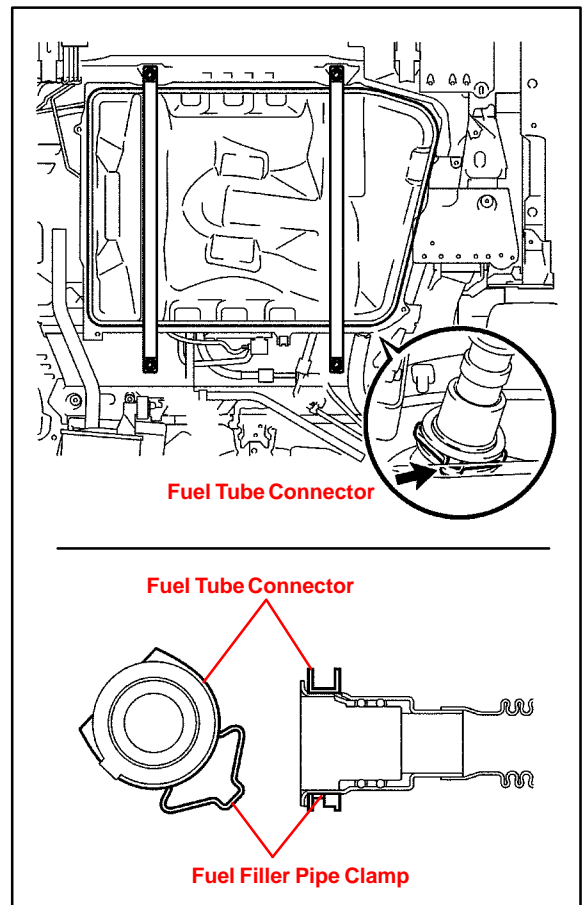

**Repair  
Procedure 2:  
Fuel Filler  
Pipe**  
(Continued)

- F. Remove the 2 bolts, then remove the fuel tank filler pipe sub-assembly.

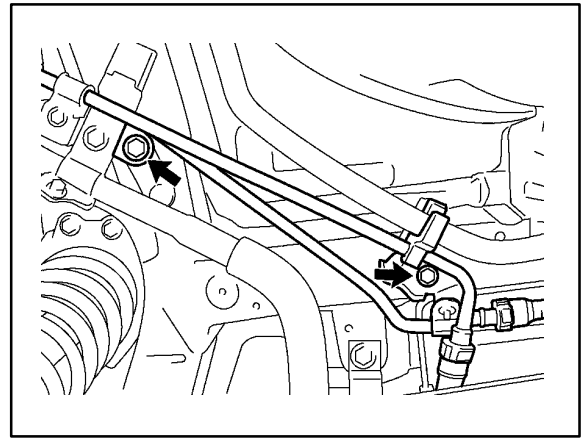

7. Transfer the following parts to the new Filler Pipe Assembly:

- Fuel inlet box rings
- Fuel tank filler pipe shield assembly
- Filler pipe clamps 1 and 2
- Fuel inlet pipe plate
- Fuel hose joint
- Fuel tank gasket
- Fuel tube connector seal
- Fuel suction tube set gasket
- Fuel tank tube
- Fuel filler pipe clamp

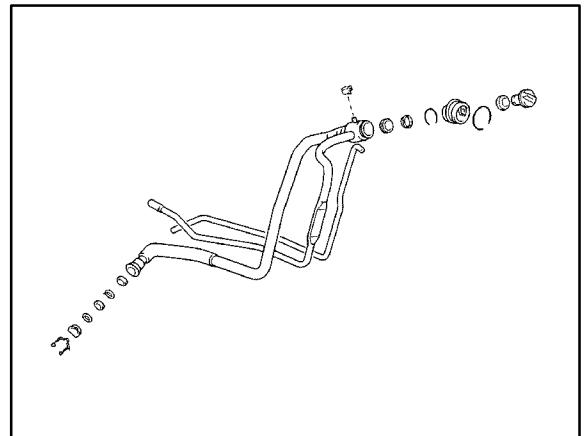

8. Install Fuel Tank Filler Pipe Sub-assembly.

- A. Install new fuel tank filler pipe sub-assembly.  
B. Tighten the 2 bolts.

**Torque A:**  
34 N•m (347 kgf•cm, 25 ft•lbf)

**Torque B:**  
18 N•m (185 kg•cm, 13 ft•lbf)

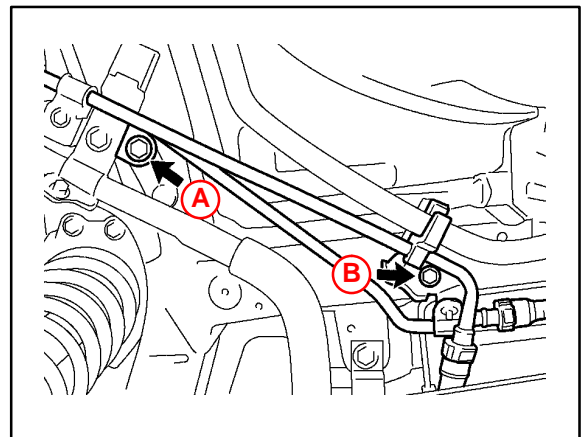

**Repair Procedure 2:  
Fuel Filler Pipe**  
(Continued)

- C. Install the fuel tube connector and fuel filler pipe clamp to the fuel tank inlet pipe.

**NOTE:**

- Securely lock the fuel filler pipe clamp.
- After locking the fuel filler pipe clamp, check that the fuel tube connector is securely installed by pulling the fuel tube in the removal direction.

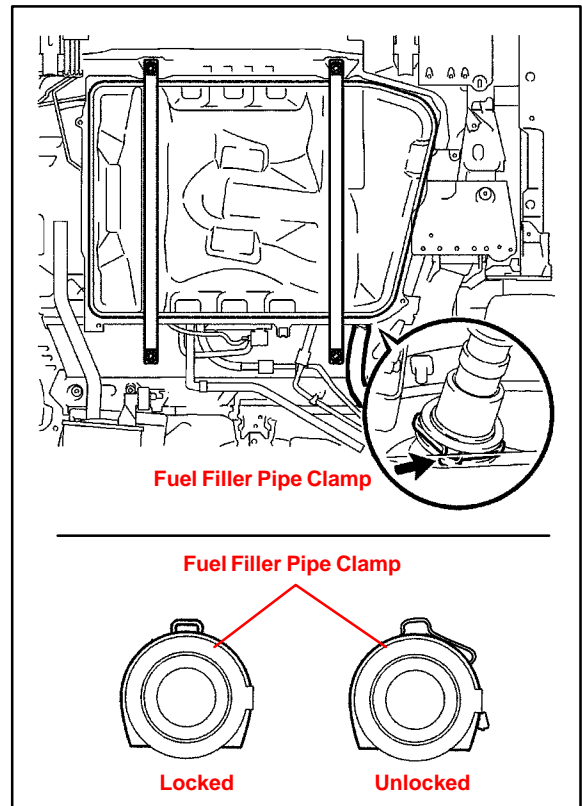

**NOTE:**

**Before reconnecting each quick connector:**

- Check that there are no scratches or foreign objects in or around the contact area of the quick connector and pipe.
- After reconnection, check that the connector is tight by pulling the quick connector in the removal direction.

- D. Connect the charcoal canister tube No. 1.
- a. Align the quick connector with the pipe, then push in the connector until the retainer makes a “click” sound.

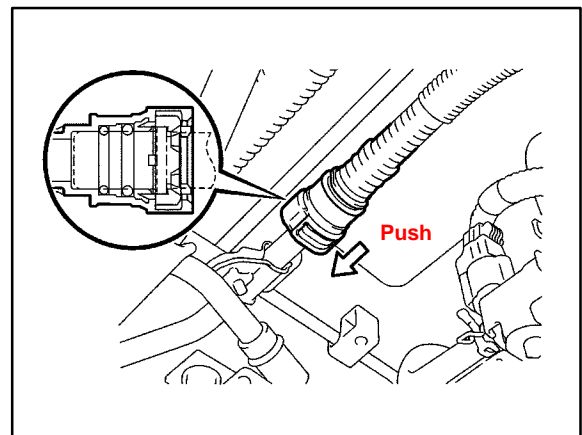

**Repair  
Procedure 2:  
Fuel Filler  
Pipe  
(Continued)**

- E. Connect the fuel suction tube.
  - a. Align the quick connector with the pipe, then push in the connector until the retainer makes a “click” sound.

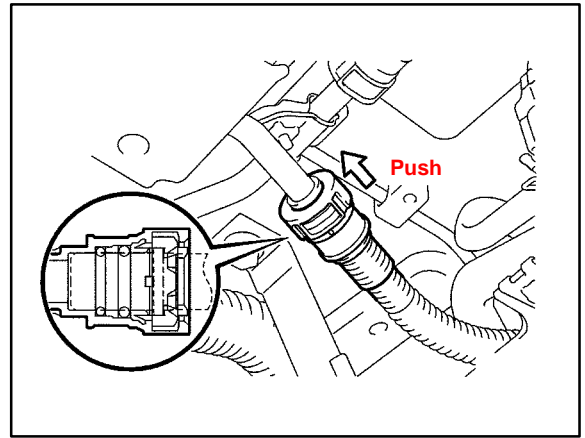

- F. Install the fuel tank vent hose (fuel tank side) to the clamp.

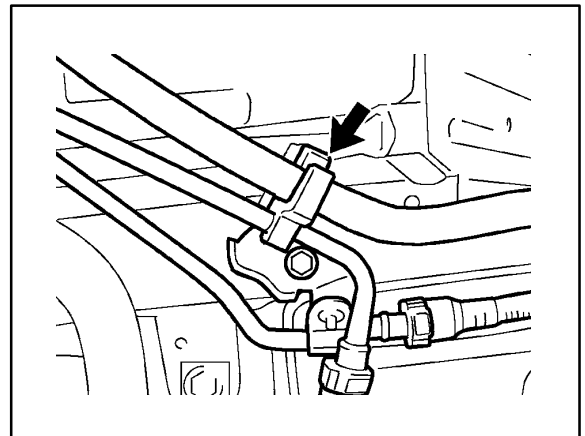

- G. Connect the fuel tank vent hose (fuel tank inlet pipe side).
  - a. Align the fuel tank vent connector No. 2 with the pipe, then push in the connector until the retainer makes a “click” sound.

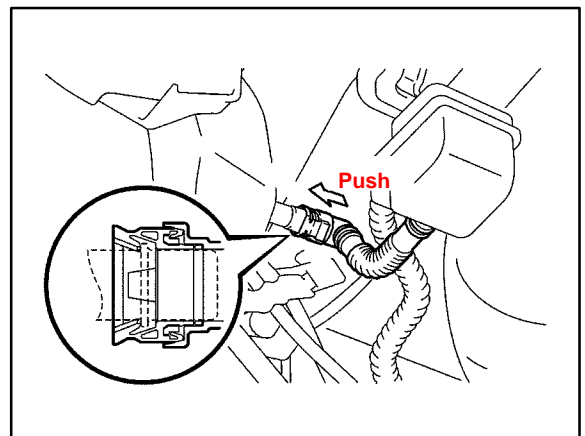

**Repair  
Procedure 2:  
Fuel Filler  
Pipe  
(Continued)**

9. Install Fuel Tank Filler Pipe Protector.
  - A. Install the fuel tank filler pipe protector with the nut.

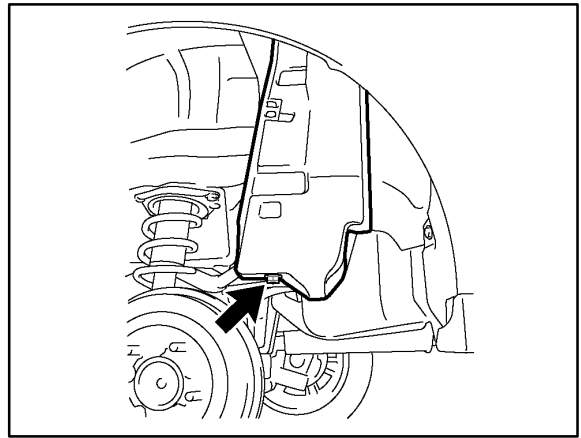

10. Install Floor Under Cover No. 1.
  - A. Install the floor under cover No. 1 with the 2 clips and 2 bolts.

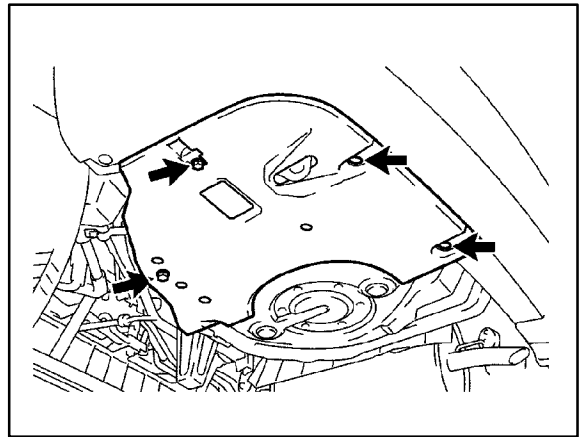

11. Install Fuel Tank Cap Assembly.
12. Install Left Rear Tire.