

# BRAKE FLUID

## BLEEDING

32152-01

### CAUTION:

Bleeding without the hand-held tester may result in the air not being completely bled. As this can result in an accident, be sure to use the hand-held tester for air bleeding.

### NOTICE:

- Move the shift lever to the P position and apply the parking brake before bleeding air.
- Add brake fluid carefully so that it remains between MIN and MAX lines of the reservoir while bleeding air.
- Brake fluid may overflow when bleeding the brake actuator hose. Do not place the fluid can on the reservoir inlet.
- If the pump motor operates while there is air remaining inside the brake actuator hose, the air will enter the actuator, resulting in difficulty in air bleeding. Remove the motor relay No.1 and No.2 until instructed to reinstall them in order to prevent air from coming into the brake actuator hose.
- Actuator pump motor and master pressure cut-off solenoid can operate through a supplemental power source even if the power switch is off.
- A buzzer may sound due to the accumulator pressure decline during air bleeding, however, keep on bleeding.
- DTCs for things such as the motor relay No.1 and No.2 malfunction and a pressure sensor malfunction are stored after bleeding. Clear the DTCs when instructed during or after bleeding.
- Bleed the brake actuator hose if air enters as a result of the decline of reservoir fluid.

### 1. PREPARATION

- (a) Move the shift lever to the P position and apply the parking brake.

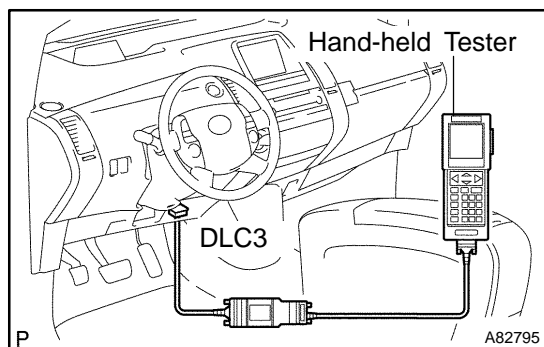

- (b) Connect the hand-held tester to the DLC3 with the power switch off as shown in the illustration.
- (c) Turn the power switch on (IG) and turn on the hand-held tester.

### NOTICE:

**Do not start the engine.**

- (d) Select "DIAGNOSTIC MENU" "ABS/VSC" "AIR BLEEDING" on the hand-held tester.

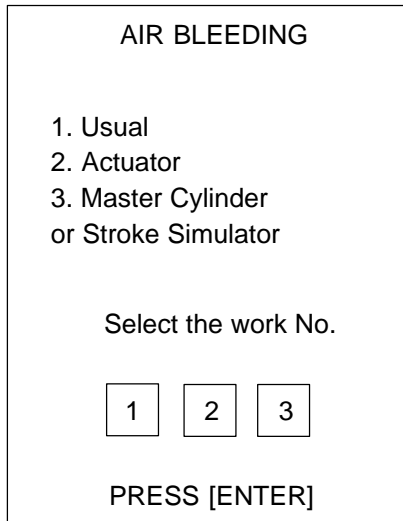

(e) Select "AIR BLEEDING".

- (1) Select "Usual" if the front/rear brakes were removed, installed or disassembled.

HINT:

Go to "4. BLEED FRONT AND REAR BRAKE SYSTEMS" if "Usual" is selected.

- (2) Select "Actuator" if the actuator is removed, installed or replaced.

**NOTICE:**

**Be sure to release the pressure out of the actuator before removing. See "5. BLEED BRAKE ACTUATOR" for bleeding instructions.**

HINT:

Go to "5. BLEED BRAKE ACTUATOR" if "Actuator" is selected.

- (3) Select "Master Cylinder or Stroke Simulator" if the brake master cylinder or the brake stroke simulator was removed, installed or replaced.

HINT:

Go to "6. BLEED MASTER CYLINDER/STROKE SIMULATOR" if "Master Cylinder or Stroke Simulator" is selected.

- (f) Return to "MENU" and bleed the air again if the display shown on the left appears during air bleeding.

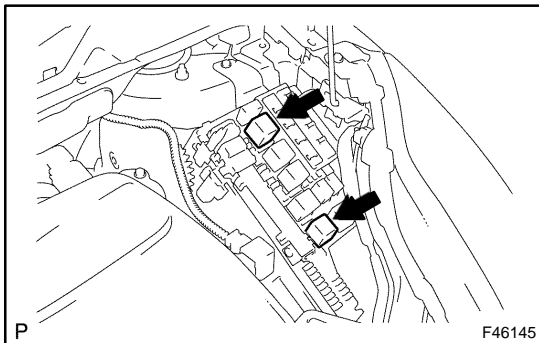

- (g) Remove and install the relays as shown in the illustration if instructed to remove and install motor relays No.1 and No.2 by the hand-held tester.

## 2. FILL RESERVOIR WITH BRAKE FLUID

### NOTICE:

Wash brake fluid off immediately if it adheres to any painted surface.

- (a) Add brake fluid into the reservoir.

Fluid: SAE J1703 or FMVSS No. 116 DOT3

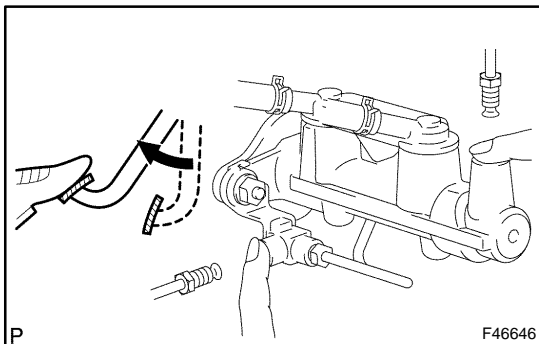
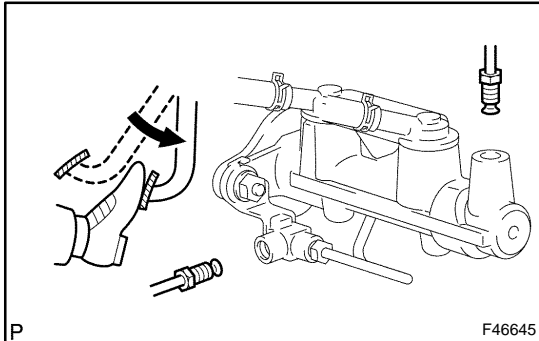

## 3. BLEED MASTER CYLINDER

### HINT:

If the master cylinder has been disassembled or if the reservoir becomes empty, bleed the air out of the master cylinder.

- (a) Disconnect the brake lines from the master cylinder.

SST 09023-00100

- (b) Slowly depress and hold the brake pedal.

- (c) Cover the outer holes with your fingers, and release the brake pedal.

- (d) Repeat (b) and (c) 3 or 4 times.

- (e) Connect the brake lines from the master cylinder.

SST 09023-00100

Torque: 15 N·m (155 kgf·cm, 11 ft·lbf)

### OPERATION

1. Turn the IG OFF.
2. Remove the motor relays No.1 and No.2.
3. Turn the IG ON.

PRESS [ENTER]

## 4. BLEED FRONT AND REAR BRAKE SYSTEMS

### NOTICE:

Wash brake fluid off immediately if it adheres to any painted surface.

### HINT:

Bleed the air out of the front and rear brake systems in accordance with the display on the left.

- (a) Remove the motor relays No.1 and No.2.

### NOTICE:

- Remove motor relays No.1 and No.2 before bleeding the air out of the front brake system.
- Be sure to turn the power switch off before removing motor relays No.1 and No.2.

## OPERATION

Perform the usual  
air bleeding for  
FR and FL wheels.

PRESS [ENTER]

- (b) Bleed the air out of the FR/FL wheels if the display shown on the left appears.
- (1) Remove the bleeder plug cap.
  - (2) Connect the vinyl tube to the bleeder plug.
  - (3) Depress the brake pedal several times, then loosen the bleeder plug with the pedal depressed.
  - (4) When the fluid stops coming out, tighten the bleeder plug, and then release the brake pedal.

**Torque: 8.4 N·m (86 kgf·cm, 74 in.-lbf)**

- (5) Repeat (3) and (4) until all the air in the fluid is completely bled out.
- (6) Install the bleeder plug cap.
- (7) Repeat the previous procedures to bleed the air out of the brake line for each wheel.

## OPERATION

1. Turn the IG OFF.
2. Install the motor relays No.1 and No.2.
3. Turn the IG ON.

PRESS [ENTER]

- (c) Install the motor relays No.1 and No.2.

**NOTICE:**

- **Install motor relays No.1 and No.2 before bleeding the air out of the rear brake system.**
- **Be sure to turn the power switch off before installing motor relays No.1 and No.2.**

## OPERATION

Hold the brake  
pedal depressed and  
loosen the bleeder  
plug of RL wheel  
until all the air  
in the fluid is  
completely bled  
out.

PRESS [ENTER]

- (d) Bleed the air out of the RL wheel if the display shown on the left appears.
- (1) Remove the bleeder plug cap of RL wheel.
  - (2) Connect the vinyl tube to the bleeder plug of RL wheel.
  - (3) Depress the brake pedal and loosen the bleeder plug of RL wheel until all the air in the fluid is completely bled out.

**NOTICE:**

**Do not pump the brake pedal. Hold the brake pedal depressed when bleeding the air out of the rear brake systems.**

**HINT:**

The actuator motor relay starts operation and oil pressure is applied to the rear brake systems if the brake pedal is depressed, which allows air bleeding through the bleeder plug.

- (4) Tighten the bleeder plug if the air is completely bled out.

**Torque: 8.4 N·m (86 kgf·cm, 74 in.-lbf)**

## OPERATION

Hold the brake pedal depressed and loosen the bleeder plug of RR wheel until all the air in the fluid is completely bled out.

PRESS [ENTER]

- (e) Bleed the air out of the RR wheel if the display shown on the left appears.
- (1) Remove the bleeder plug cap of RR wheel.
  - (2) Connect the vinyl tube to the bleeder plug of RR wheel.
  - (3) Depress the brake pedal and loosen the bleeder plug of RR wheel until all the air in the fluid is completely bled out.

**NOTICE:**

**Do not pump the brake pedal. Hold the brake pedal depressed when bleeding the air out of the rear brake systems.**

**HINT:**

The actuator motor relay starts operation and oil pressure is applied to the rear brake systems if the brake pedal is depressed, which allows air bleeding through the bleeder plug.

Air Bleeding is  
COMPLETE.

PRESS [ENTER]

- (f) The air bleeding of the front and rear brake system finishes if the display shown on the left appears.

## INFORMATION

Do you wish to refresh the high pressure line?

This operation will take 20 seconds.

PRESS [ENTER]

**5. BLEED BRAKE ACTUATOR****NOTICE:**

**Wash brake fluid off immediately if it adheres to any painted surface.**

**HINT:**

Bleed the air out of the brake actuator in accordance with the display on the left.

- (a) Refresh the high pressure line.

**NOTICE:**

**Be sure to perform this procedure before replacement, removal or installation of the actuator.**

**HINT:**

- Decrease the internal pressure by performing this procedure.
- Count down from 20 seconds.

## OPERATION

1. Turn the IG OFF.
2. Remove the motor relays No.1 and No.2
3. Turn the IG ON.
4. Confirm ABS pump motor runs and stops.

PRESS [ENTER]

(b) Follow the procedures shown on the display on the left.

**NOTICE:**

**Be sure to remove motor relays No.1 and No.2 before removing the actuator for replacement, removal or installation.**

## OPERATION

Perform the usual air bleeding for FR and FL wheels.

PRESS [ENTER]

(c) Follow the procedures shown on the display on the left.

**HINT:**

See "4. BLEED FRONT AND REAR BRAKE SYSTEMS" for bleeding the air out of the front brake system.

## INFORMATION

Do you wish to bleed the air out of the drain line?

This command activates solenoids (SLRFR, SLRFL, SLRRR and SLRRL).

PRESS [ENTER]

(d) Bleed the air out of the drain line.

**NOTICE:**

**Be sure to perform this procedure if air remains in the actuator hose.**

**HINT:**

Fluid inside the actuator hose returns to the reservoir tank when performing this procedure.

## OPERATION

1. Depress the brake pedal 30 times in 30 seconds.
2. Turn the IG OFF.
3. Install the motor relays No.1 and No.2
4. Turn the IG ON.

PRESS [ENTER]

- (e) Depress the brake pedal 30 times within 30 seconds while the solenoid is operating.

## HINT:

The solenoid stops operation automatically after approximately 30 seconds.

- (f) Install the motor relays No.1 and No.2.

**NOTICE:**

- **Install motor relays No.1 and No.2 before bleeding the air out of the rear brake system.**
- **Be sure to turn the power switch off before installing motor relays No.1 and No.2.**

## OPERATION

Hold the brake pedal depressed and loosen the bleeder plug of RL wheel until all the air in the fluid is completely bled out.

PRESS [ENTER]

- (g) Bleed the air out of the rear brake RL wheel.

## HINT:

See "4. BLEED FRONT AND REAR BRAKE SYSTEMS" for bleeding the air out of the rear brake system.

## OPERATION

Hold the brake pedal depressed and loosen the bleeder plug of RR wheel until all the air in the fluid is completely bled out.

PRESS [ENTER]

- (h) Bleed the air out of the rear brake RR wheel.

## HINT:

See "4. BLEED FRONT AND REAR BRAKE SYSTEMS" for bleeding the air out of the rear brake system.

## OPERATION

Loosen the bleeder  
plug of FL wheel.

PRESS [ENTER]

- (i) Loosen the bleeder plug of FL wheel.

## INFORMATION

Do you wish to  
bleed the air out  
of the power  
supply line?

This command  
activates solenoids  
(SMC2 and SLAFL).

PRESS [ENTER]

- (j) Bleed the air out of the power supply line.

## HINT:

Air can be bled out of the high pressure line inside the actuator when performing this procedure.

## OPERATION

Tighten the bleeder  
plug of FL wheel.

PRESS [ENTER]

- (k) Tighten the bleeder plug of FL wheel.  
**Torque: 8.4 N·m (86 kgf·cm, 74 in·lbf)**



INFORMATION  
(\*2)

Do you wish to bleed the air out of the stroke simulator line?

This command activates solenoids (SMC2 and SCSS).

PRESS [ENTER]

(I) Bleed the air out of the stroke simulator line.

HINT:

- See "6. BLEED BRAKE MASTER CYLINDER/STROKE SIMULATOR" for bleeding the air out of the stroke simulator.
- Bleed the air out of the stroke simulator twice.
- The number of times air is bled is displayed as 1/2 (first) and 2/2 (second).

OPERATION  
(\*2)

Depress the brake pedal 20 times in 20 seconds.

PRESS [ENTER]

(1) Depress the brake pedal 20 times in 20 seconds.

HINT:

Depress the brake pedal 20 times at 1 second intervals, holding the pedal down on the last time.

OPERATION  
(\*2)

Perform the usual air bleeding for FL wheel.

PRESS [ENTER]

(2) Perform the usual air bleeding for FL wheel.

HINT:

- Loosen the bleeder plug of the FL wheel and bleed the air with the brake pedal depressed.
- See "4. BLEED FRONT AND REAR BRAKE SYSTEMS" for bleeding instructions.

INFORMATION  
(\*5)

Do you wish to  
refresh the  
high pressure line?

This operation  
will take  
20 seconds.

PRESS [ENTER]

(m) Refresh the high pressure line.

**NOTICE:**

**Keep the fluid inside the reservoir above the "LOW" level by replenishing.**

**HINT:**

- Accumulator pressure is released and accumulated repeatedly, which circulates the fluid inside the accumulator when performing this procedure.
- The high pressure line is refreshed 5 times. The number of times refreshed is displayed as 1/5 (first), 2/5 (second) and so on.
- Count down from 20 seconds.

OPERATION  
(\*5)

1. Turn the IG OFF, and ON again.
2. Confirm the ABS motor pump runs and stops.

PRESS [ENTER]

(n) Turn the power switch off. Turn the power switch on (IG) and check if the ABS motor pump runs and stops.

**HINT:**

The pump motor rotates and the accumulator is pressurized every time turning the power switch from off to on (IG).

(o) Return to "MENU".

OPERATION

1. Turn the IG OFF.
2. Remove the motor relays No.1 and No.2.
3. Turn the IG ON.

PRESS [ENTER]

**6. BLEED MASTER CYLINDER/STROKE SIMULATOR**

**NOTICE:**

**Wash brake fluid off immediately if it adheres to any painted surface.**

**HINT:**

Bleed the air out of the master cylinder/stroke simulator in accordance with the display shown on the left.

(a) Remove the motor relays No.1 and No.2.

**NOTICE:**

- **Remove motor relays No.1 and No.2 before bleeding the air out of the front brake system.**
- **Be sure to turn the power switch off before removing motor relays No.1 and No.2.**

## OPERATION

Perform the usual  
air bleeding for  
FR and FL wheels.

PRESS [ENTER]

- (b) Bleed the air out of the FR/FL wheels in accordance with the display shown on the left.

## HINT:

- Air can be completely bled out of the master cylinder by performing this procedure.
- See "4. BLEED FRONT AND REAR BRAKE SYSTEMS" for bleeding instructions.

## OPERATION

1. Turn the IG OFF.
2. Install the motor relays No.1 and No.2.
3. Turn the IG ON.

PRESS [ENTER]

- (c) Install the motor relays No.1 and No.2.

**NOTICE:**

- **Install motor relays No.1 and No.2 before bleeding the air out of the stroke simulator.**
- **Be sure to turn the power switch off before installing motor relays No.1 and No.2.**

INFORMATION  
(\*2)

Do you wish to  
bleed the air out  
of the stroke  
simulator line?

This command  
activates solenoids  
(SMC2 and SCSS).

PRESS [ENTER]

- (d) Bleed the air out of the stroke simulator line.

## HINT:

- Bleed the air out of the stroke simulator twice.
- The number of times air is bled is displayed as 1/2 (first) and 2/2 (second).

OPERATION  
(\* / 2)

Depress the brake pedal 20 times in 20 seconds.

PRESS [ENTER]

(1) Depress the brake pedal 20 times in 20 seconds.

HINT:

Depress the brake pedal 20 times at 1 second intervals, holding the pedal down on the last time.

OPERATION  
(\* / 2)

Perform the usual air bleeding for FL wheel.

PRESS [ENTER]

(2) Perform the usual air bleeding for FL wheel.

HINT:

- Loosen the bleeder plug of the FL wheel and bleed the air with the brake pedal depressed.
- See "4. BLEED FRONT AND REAR BRAKE SYSTEMS" for bleeding instructions.

Air Bleeding is COMPLETE.

PRESS [ENTER]

(e) The air bleeding of the master cylinder/stroke simulator finishes if the display shown on the left appears.

## 7. CHECK AND CLEAR DTC (SEE PAGE [05-973](#) )