

TERMINALS OF ECU

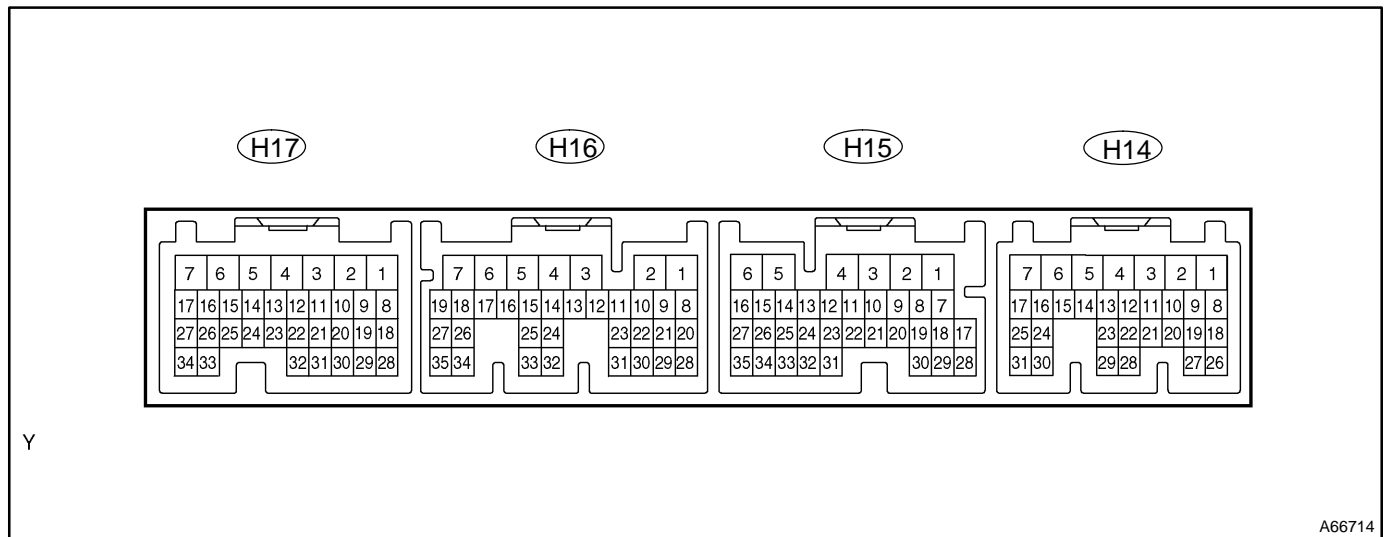

Symbols (Terminals No.)	Wiring Color	Terminal Description	Condition	STD Voltage (V)
ST2 (H14-5) - GND1 (H14-1)	Y - W-B	Starter signal	Power switch ON (READY)	9 to 14
IGSW (H14-7) - GND1 (H14-1)	O - W-B	IG signal	Power switch ON (IG)	9 to 14
BATT (H15-6) - GND1 (H14-1)	Y - W-B	Auxiliary battery (for measuring the battery voltage and for the HV control ECU memory)	Always	9 to 14
+B1 (H16-7) - GND1 (H14-1)	L - W-B	Power source of HV control ECU	Power switch ON (IG)	9 to 14
+B2 (H16-6) - GND1 (H14-1)	L - W-B	Power source of HV control ECU	Power switch ON (IG)	9 to 14
MREL (H16-4) - GND1 (H14-1)	O - W-B	Main relay	Power switch ON (IG)	9 to 14
CANH (H14-8) - GND1 (H14-1)	B - W-B	HIGH-level CAN bus line	Power switch ON (IG)	Pulse generation (see waveform 1)
CANL (H14-9) - GND1 (H14-1)	W - W-B	LOW-level CAN bus line	Power switch ON (IG)	Pulse generation (see waveform 2)
NEO (H16-12) - GND1 (H14-1)	LG - W-B	Engine speed signal	Engine running	Pulse generation (see waveform 3)
GO (H16-13) - GND1 (H14-1)	Y - W-B	G signal	Engine running	Pulse generation (see waveform 4)
SPDI (H14-19) - GND1 (H14-1)	V - W-B	Vehicle speed signal	Driving at approximately 12 mph (20 km/h)	Pulse generation (see waveform 5)
VPA1 (H16-26) - EP1 (H16-27)	L - B	Accelerator pedal position sensor (for the HV system)	Power switch ON (IG), accelerator pedal released	0.5 to 1.1
VPA1 (H16-26) - EP1 (H16-27)	L - B	Accelerator pedal position sensor (for the HV system)	Power switch ON (IG), engine stopped in P position, accelerator pedal fully depressed	2.6 to 4.5
VPA2 (H16-34) - EP2 (H16-35)	W - R	Accelerator pedal position sensor (for the sensor malfunction detection)	Power switch ON (IG), accelerator pedal fully depressed	1.2 to 2.0
VPA2 (H16-34) - EP2 (H16-35)	W - R	Accelerator pedal position sensor (for the sensor malfunction detection)	Power switch ON (IG), engine stopped in P position, accelerator pedal released	3.4 to 5.3
VCP1 (H16-25) - EP1 (H16-27)	Y - B	Power source of accelerator pedal position sensor (for VPA1)	Power switch ON (IG)	4.5 to 5.5

DIAGNOSTICS - HYBRID CONTROL SYSTEM

Symbols (Terminals No.)	Wiring Color	Terminal Description	Condition	STD Voltage (V)
VCP2 (H16-33) - EP2 (H16-35)	G - R	Power source of accelerator pedal position sensor (for VPA2)	Power switch ON (IG)	4.5 to 5.5
VSX1 (H14-25) - E2X1 (H14-15)	B - R	Shift position sensor (main)	Power switch ON (IG), selector lever home position	2.0 to 3.0
VSX1 (H14-25) - E2X1 (H14-15)	B - R	Shift position sensor (main)	Power switch ON (IG), selector lever moved to R position	4.0 to 4.8
VSX1 (H14-25) - E2X1 (H14-15)	B - R	Shift position sensor (main)	Power switch ON (IG), selector lever moved to B or D position	0.2 to 1.0
VSX2 (H14-24) - E2X2 (H14-14)	L - Y	Shift position sensor (sub)	Power switch ON (IG), selector lever home position	2.0 to 3.0
VSX2 (H14-24) - E2X2 (H14-14)	L - Y	Shift position sensor (sub)	Power switch ON (IG), selector lever moved to R position	4.0 to 4.8
VSX2 (H14-24) - E2X2 (H14-14)	L - Y	Shift position sensor (sub)	Power switch ON (IG), selector lever moved to B or D position	0.2 to 1.0
VCX1 (H14-17) - E2X1 (H14-15)	W - R	Power source of shift position sensor (for VSX1)	Power switch ON (IG)	4.5 to 5.5
VCX2 (H14-16) - E2X2 (H14-14)	G - Y	Power source of shift position sensor (for VSX2)	Power switch ON (IG)	4.5 to 5.5
VSX3 (H14-23) - GND1 (H14-1)	BR - W-B	Select position sensor (main)	Power switch ON (IG), selector lever home position	0.5 to 2.0
VSX3 (H14-23) - GND1 (H14-1)	BR - W-B	Select position sensor (main)	Power switch ON (IG), selector lever moved to R, N or D position	3.0 to 4.85
VSX4 (H14-30) - GND1 (H14-1)	SB - W-B	Select position sensor (sub)	Power switch ON (IG), selector lever home position	0.5 to 2.0
VSX4 (H14-30) - GND1 (H14-1)	SB- W-B	Select position sensor (sub)	Power switch ON (IG), selector lever moved to R, N or D position	3.0 to 4.85
VCX3 (H14-21) - GND1 (H14-1)	W - W-B	Power source of select position sensor (for VSX3)	Power switch ON (IG)	9 to 14
VCX4 (H14-31) - GND1 (H14-1)	P - W-B	Power source of select position sensor (for VSX4)	Power switch ON (IG)	9 to 14
NODD (H16-24) - GND1 (H14-1)	V - W-B	DC/DC movement monitor or stop request signal	When converter is in normal operation	5 to 7
NODD (H16-24) - GND1 (H14-1)	V - W-B	DC/DC movement monitor or stop request signal	When converter is improper	2 to 4
NODD (H16-24) - GND1 (H14-1)	V - W-B	DC/DC movement monitor or stop request signal	When converter is required to stop	0.1 to 0.5
VLO (H16-31) - GND1 (H14-1)	L - W-B	Two-stage selector signal	Converter switching to 14 V output	13 to 14
VLO (H16-31) - GND1 (H14-1)	L - W-B	Two-stage selector signal	Converter switching to 13.5 V output	Below 0.5
TC (H14-6) - GND1 (H14-1)	P - W-B	Terminal TC of DLC3	Power switch ON (IG)	9 to 14
STP (H15-3) - GND1 (H14-1)	L - W-B	Stop lamp switch	Brake pedal depressed	9 to 14
STP (H15-3) - GND1 (H14-1)	L - W-B	Stop lamp switch	Brake pedal released	2 to 3
ABFS (H14-20) - GND1 (H14-1)	L - W-B	Airbag deployment signal	Power switch ON (READY) (2 seconds after ACC ON)	Pulse generation (see waveform 6 to 8)
AS1 (H16-15) - AS1G (H16-16)	Y - W	Circuit breaker sensor No. 1	Satellite signal system normal	2.5 to 2.9
ILK (H15-1) - GND1 (H14-1)	V - W-B	Interlock switch	Power switch ON (IG), inverter cover and service plug grip installed normally	Below 1

Symbols (Terminals No.)	Wiring Color	Terminal Description	Condition	STD Voltage (V)
ILK (H15-1) - GND1 (H14-1)	V - W-B	Interlock switch	Power switch ON (IG), inverter cover or service plug grip detached	9 to 14
CON1 (H16-1) - GND1 (H14-1)	R - W-B	System main relay No. 1	Power switch OFF to ON (READY)	Pulse generation (see waveform 9)
CON2 (H16-2) - GND1 (H14-1)	G - W-B	System main relay No. 2	Power switch OFF to ON (READY)	Pulse generation (see waveform 9)
CON3 (H16-3) - GND1 (H14-1)	Y - W-B	System main relay No. 3	Power switch OFF to ON (READY)	Pulse generation (see waveform 9)
VH (H15-26) - GINV (H15-23)	Y - W-B	Inverter condenser voltage monitor	Power switch ON (READY)	1.6 to 3.8
GUU (H15-15) - GINV (H15-23)	B - Y	Generator switch U signal	Power switch ON (IG)	Pulse generation (see waveform 10)
GVU (H15-14) - GINV (H15-23)	G - Y	Generator switch V signal	Power switch ON (IG)	Pulse generation (see waveform 10)
GWU (H15-13) - GINV (H15-23)	Y - Y	Generator switch W signal	Power switch ON (IG)	Pulse generation (see waveform 10)
GIVA (H15-34) - GINV (H15-23)	W - Y	Generator V phase current	Power switch ON (IG)	Approximately 0
GIVB (H15-33) - GINV (H15-23)	B - Y	Generator V phase current	Power switch ON (IG)	Approximately 0
GIWA (H15-32) - GINV (H15-23)	R - Y	Generator W phase current	Power switch ON (IG)	Approximately 0
GIWB (H15-31) - GINV (H15-23)	G - Y	Generator W phase current	Power switch ON (IG)	Approximately 0
GIVT (H15-27) - GINV (H15-23)	W - Y	Generator inverter temperature sensor	Power switch ON (IG)	2 to 4.5
GSDN (H15-16) - GINV (H15-23)	R - W-B	Generator shutdown signal	Power switch ON (READY), N position	0.2 to 0.7
GSDN (H15-16) - GINV (H15-23)	R - W-B	Generator shutdown signal	Power switch ON (READY), P position	5.1 to 13.6
GFIV (H15-35) - GINV (H15-23)	GR - W-B	Generator inverter fail signal	Power switch ON (IG), inverter normal	5.4 to 7.4
GFIV (H15-35) - GINV (H15-23)	GR - W-B	Generator inverter fail signal	Power switch ON (IG), inverter abnormal	2 to 3
GRF (H17-27) - GRFG (H17-26)	B - W	Generator resolver signal	Generator resolver stopped or rotating	Pulse generation (see waveform 11, 12)
GSN (H17-22) - GSNG (H17-21)	R - G	Generator resolver signal	Generator resolver stopped or rotating	Pulse generation (see waveform 11, 12)
GCS (H17-23) - GCSG (H17-24)	Y - BR	Generator resolver signal	Generator resolver stopped or rotating	Pulse generation (see waveform 11, 12)
OMT (H17-30) - OMTG (H17-29)	B - G	Motor temperature sensor No. 2	Refer to DATA LIST on page 05-434	-
MUU (H15-9) - GINV (H15-23)	B - Y	Motor switch U signal	Power switch ON (IG)	Pulse generation (see waveform 13)
MVU (H15-10) - GINV (H15-23)	W - Y	Motor switch V signal	Power switch ON (IG)	Pulse generation (see waveform 13)
MWU (H15-11) - GINV (H15-23)	R - Y	Motor switch W signal	Power switch ON (IG)	Pulse generation (see waveform 13)
MIVA (H15-30) - GINV (H15-23)	G - Y	Motor V phase current	Power switch ON (IG)	Approximately 0
MIVB (H15-21) - GINV (H15-23)	W - Y	Motor V phase current	Power switch ON (IG)	Approximately 0
MIWA (H15-29) - GINV (H15-23)	R - Y	Motor W phase current	Power switch ON (IG)	Approximately 0

DIAGNOSTICS - HYBRID CONTROL SYSTEM

Symbols (Terminals No.)	Wiring Color	Terminal Description	Condition	STD Voltage (V)
MIWB (H15-20) - GINV (H15-23)	B - Y	Motor W phase current	Power switch ON (IG)	Approximately 0
MIVT (H15-19) - GINV (H15-23)	L - Y	Motor inverter temperature sensor	Power switch ON (IG)	2 to 4.5
MSDN (H15-8) - GINV (H15-23)	G - W-B	Motor shutdown signal	Power switch ON (READY), N position	0.2 to 0.7
MSDN (H15-8) - GINV (H15-23)	G - W-B	Motor shutdown signal	Power switch ON (READY), P position	5.1 to 13.6
OVH (H15-22) - GINV (H15-23)	BR - W-B	Motor inverter over voltage signal	Power switch ON (IG), inverter normal	5.3 to 7.3
OVH (H15-22) - GINV (H15-23)	BR - W-B	Motor inverter over voltage signal	Power switch ON (IG), inverter abnormal	1.9 to 2.9
MFIV (H15-18) - GINV (H15-23)	G - W-B	Motor inverter fail signal	Power switch ON (IG), inverter normal	5.4 to 7.4
MFIV (H15-18) - GINV (H15-23)	G - W-B	Motor inverter fail signal	Power switch ON (IG), inverter abnormal	2 to 3
MRF (H17-34) - MRFG (H17-33)	L - P	Motor resolver signal	Motor resolver stopped or rotating	Pulse generation (see waveform 11, 12)
MSN (H17-20) - MSNG (H17-19)	G - R	Motor resolver signal	Motor resolver stopped or rotating	Pulse generation (see waveform 11, 12)
MCS (H17-32) - MCSG (H17-31)	Y - BR	Motor resolver signal	Motor resolver stopped or rotating	Pulse generation (see waveform 11, 12)
MMT (H17-18) - MMTG (H17-28)	B - R	Motor temperature sensor No. 1	Refer to DATA LIST on page 05-434	-
VL (H16-30) - GCNV (H16-8)	Y - G	Boost converter input voltage	Power switch ON (READY)	1.9 to 3.4
OVL (H16-22) - GCNV (H16-8)	B - G	Boost converter over voltage signal	Power switch ON (IG), boost converter normal	5.3 to 7.7
OVL (H16-22) - GCNV (H16-8)	B - G	Boost converter over voltage signal	Power switch ON (IG), boost converter abnormal	1.9 to 3.0
FCV (H16-20) - GCNV (H16-8)	W - G	Boost converter fail signal	Power switch ON (IG), boost converter normal	5.3 to 7.7
FCV (H16-20) - GCNV (H16-8)	W - G	Boost converter fail signal	Power switch ON (IG), boost converter abnormal	1.9 to 3.0
CT (H16-21) - GCNV (H16-8)	R - G	Boost converter temperature sensor	Power switch ON (IG)	2.0 to 4.5
CPWM (H16-10) - GCNV (H16-8)	B - G	Boost converter PWM switch signal	Power switch ON (READY), parking brake ON, D position, brake pedal and accelerator pedal depressed	Pulse generation (see waveform 14)
CSDN (H16-9) - GCNV (H16-8)	W - G	Boost converter shutdown signal	Power switch ON (IG)	5.6 or higher
CSDN (H16-9) - GCNV (H16-8)	W - G	Boost converter shutdown signal	Power switch ON (READY)	Below 0.7
ST1- (H15-2) - GND1 (H14-1)	G - W-B	Stop lamp switch (opposite to STP)	Power switch ON (IG) and brake pedal depressed	Below 0.5
ST1- (H15-2) - GND1 (H14-1)	G - W-B	Stop lamp switch (opposite to STP)	Power switch ON (IG) and brake pedal released	9 to 14
CCS (H14-13) - GND1 (H14-1)	V - W-B	Cruise control switch	Cruise control system - Terminal of ECU - CCS terminal (see page 05-2682)	-
IMI (H14-18) - GND1 (H14-1)	W - W-B	Immobilizer communication	Immobilizer communicating	Pulse generation (see waveform 15)
IMO (H14-26) - GND1 (H14-1)	R - W-B	Immobilizer communication	Immobilizer communicating	Pulse generation (see waveform 15)
P1 (H15-17) - GND1 (H14-1)	Y - W-B	P position switch	Power switch ON (IG), P position switch ON	3 to 5

Symbols (Terminals No.)	Wiring Color	Terminal Description	Condition	STD Voltage (V)
P1 (H15-17) - GND1 (H14-1)	Y - W-B	P position switch	Power switch ON (IG), P position switch OFF	7 to 12
PCON (H17-9) - GND1 (H14-1)	LG - W-B	P position control signal	Power switch ON (IG)	Pulse generation (see waveform 16)
PPOS (H17-10) - GND1 (H14-1)	W - W-B	P position signal	Power switch ON (IG)	Pulse generation (see waveform 16)
RDY (H14-28) - GND1 (H14-1)	R - W-B	READY control signal	Power switch ON (IG)	Pulse generation (see waveform 17)
RDY (H14-28) - GND1 (H14-1)	R - W-B	READY control signal	Power switch ON (READY)	Pulse generation (see waveform 18)
CLK (H16-17) - GND1 (H14-1)	G - W-B	A/C communication	Power switch ON (IG), A/C operating	Pulse generation (see waveform 19)
ITE (H16-14) - GND1 (H14-1)	Y - W-B	A/C communication	Power switch ON (IG), A/C operating	Pulse generation (see waveform 19)
ETI (H15-24) - GND1 (H14-1)	R - W-B	A/C communication	Power switch ON (IG), A/C operating	Pulse generation (see waveform 19)
STB (H15-25) - GND1 (H14-1)	W - W-B	A/C communication	Power switch ON (IG), A/C operating	Pulse generation (see waveform 19)
WP (H16-5) - GND1 (H14-1)	O - W-B	Water pump relay control	Power switch ON (IG), A/C operating	Below 2
GND1 (H14-1) - Body ground	W-B - Body ground	Ground	Always (resistance check)	Below 5 Ω
GND2 (H14-4) - Body ground	W-B - Body ground	Ground	Always (resistance check)	Below 5 Ω

1. Oscilloscope waveforms

HINT:

In the oscilloscope waveform samples, which are provided here for informational purposes. Noise and fluttering waveforms have been omitted.

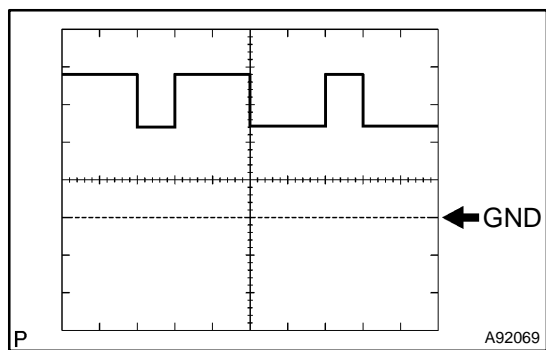

(a) Waveform 1 (HIGH-level CAN bus line)

Item	Contents
Terminal	CANH - GND1
Equipment Setting	1 V/Division, 2 μs/Division
Condition	Power switch ON (IG)

HINT:

The waveform varies depending on the contents of communication.

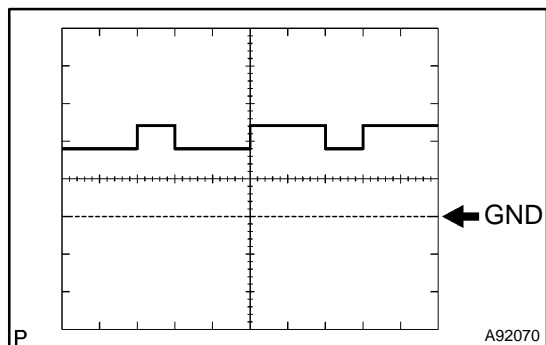

(b) Waveform 2 (LOW-level CAN bus line)

Item	Contents
Terminal	CANL - GND1
Equipment Setting	1 V/Division, 2 μs/Division
Condition	Power switch ON (IG)

HINT:

The waveform varies depending on the contents of communication.

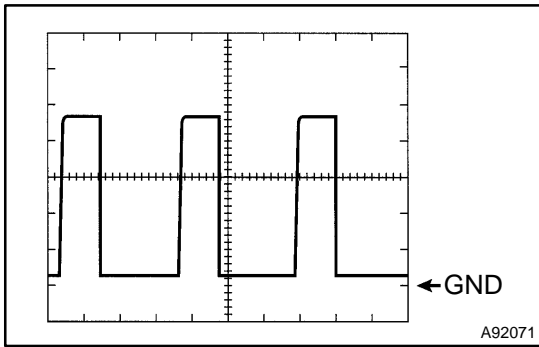

(c) Waveform 3 (engine speed signal)

Item	Contents
Terminal	NEO - GND1
Equipment Setting	1 V/Division, 2 ms/Division
Condition	Engine idling

HINT:

The pulse cycle becomes shorter as the engine speed increases.

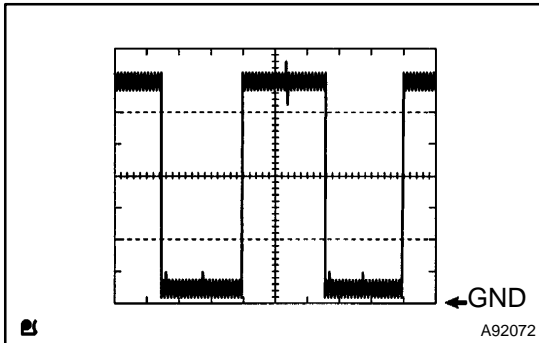

(d) Waveform 4 (G signal)

Item	Contents
Terminal	GO - GND1
Equipment Setting	2 V/Division, 20 ms/Division
Condition	Engine idling

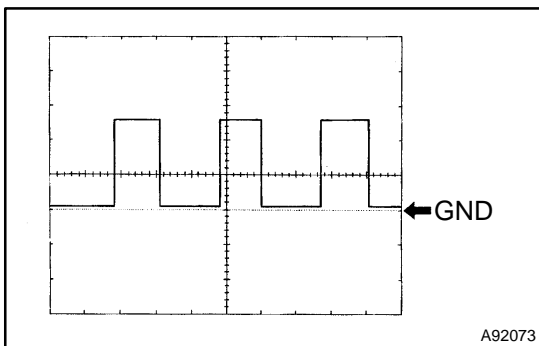

(e) Waveform 5 (vehicle speed signal)

Item	Contents
Terminal	SPDI - GND1
Equipment Setting	2 V/Division, 20 ms/Division
Condition	Driving at approximately 20 km/h (12 mph)

HINT:

The higher the vehicle speed, the shorter the cycle and higher the voltage.

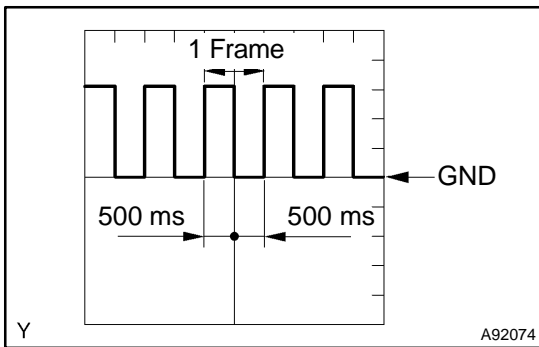

(f) Waveform 6 (airbag deployment signal)

Item	Contents
Terminal	ABFS - GND1
Equipment Setting	1 V/Division, 500 ms/Division
Condition	Power switch ON (READY) (2 seconds after ACC ON) Airbag system normal

HINT:

The waveform on the left is repeated when the airbag system is normal.

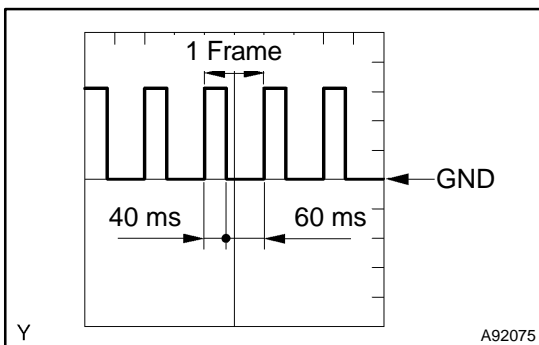

(g) Waveform 7 (airbag deployment signal)

Item	Contents
Terminal	ABFS - GND1
Equipment Setting	1 V/Division, 50 ms/Division
Condition	Power switch ON (READY) (2 seconds after ACC ON) Airbag system abnormal

HINT:

The waveform on the left is repeated when the airbag system is abnormal.

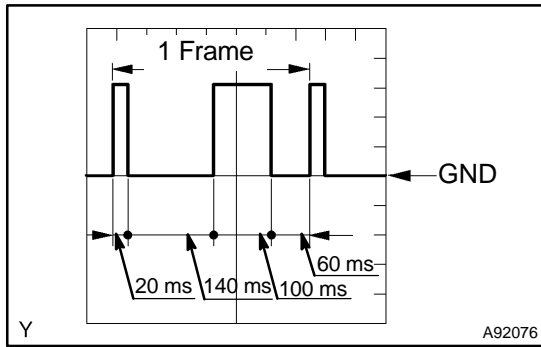

(h) Waveform 8 (airbag deployment signal)

Item	Contents
Terminal	ABFS - GND1
Equipment Setting	1 V/Division, 50 ms/Division
Condition	Power switch ON (READY) (2 seconds after ACC ON) Airbag system deployed (during collision)

HINT:

When the airbag system is deployed, after 1 frame of transmission indicating a normal condition is completed, the waveform on the left is repeated for 50 frames. After that, normal transmission returns.

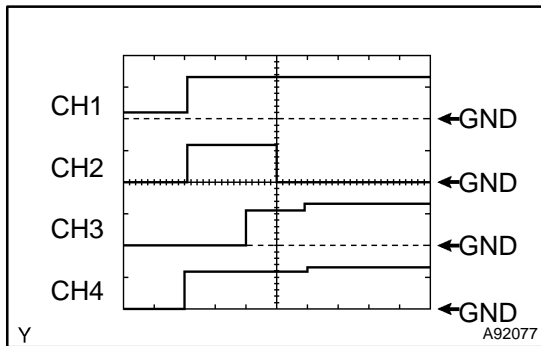

(i) Waveform 9 (system main relay signal)

Item	Contents
Terminal	CH1: IGSW - GND1 CH2: CON1 - GND1 CH3: CON2 - GND1 CH4: CON3 - GND1
Equipment Setting	10 V/Division, 100 ms/Division
Condition	Power switch OFF to ON (READY)

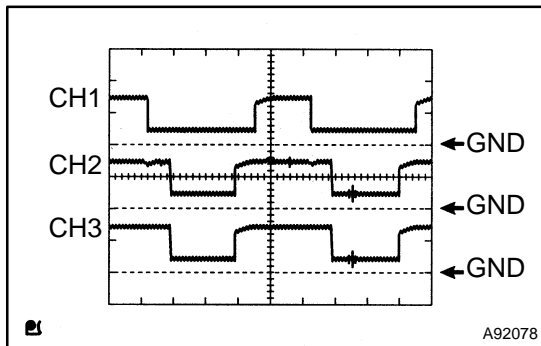

(j) Waveform 10 (generator switch U, V, and W signal)

Item	Contents
Terminal	CH1: GUU - GINV CH2: GVU - GINV CH3: GWU - GINV
Equipment Setting	10 V/Division, 20 μs/Division
Condition	Power switch ON (IG)

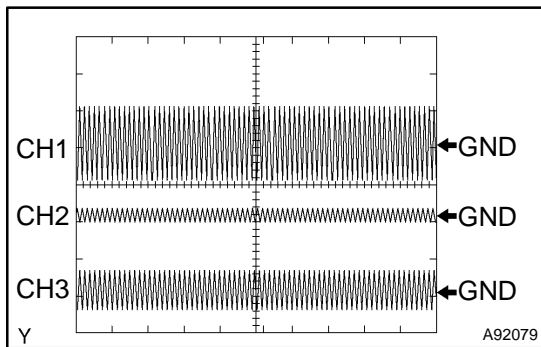

(k) Waveform 11 (generator or motor resolver)

Item	Contents
Terminal (Generator Resolver)	CH1: GRF - GRFG CH2: GSN - GSNG CH3: GCS - GCSG
Terminal (Motor Resolver)	CH1: MRF - MRFG CH2: MSN - MSNG CH3: MCS - MCSG
Equipment Setting	CH1: 10 V/Division, 1 ms/Division CH2, 3: 5 V/Division, 1 ms/Division
Condition	Generator or motor stopped

HINT:

The phases and the waveform height of the GSN and GCS, or the MSN and MCS change depending on the stopped position of rotor.

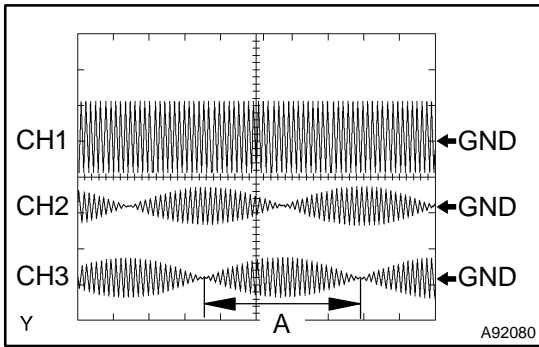

(l) Waveform 12 (generator or motor resolver)

Item	Contents
Terminal (Generator Resolver)	CH1: GRF - GRFG CH2: GSN - GSNG CH3: GCS - GCSG
Terminal (Motor Resolver)	CH1: MRF - MRFG CH2: MSN - MSNG CH3: MCS - MCSG
Equipment Setting	CH1: 10 V/Division, 1 ms/Division CH2, 3: 5 V/Division, 1 ms/Division
Condition	Generator or motor stopped

HINT:

Distance "A" in the diagram becomes shorter as the rotor speed increases.

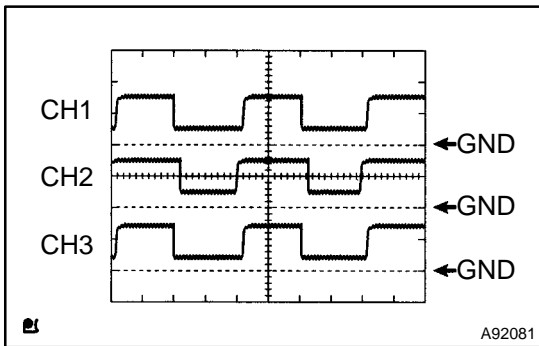

(m) Waveform 13 (motor switch U, V, and W signal)

Item	Contents
Terminal	CH1: MUU - GINV CH2: MVU - GINV CH3: MWU - GINV
Equipment Setting	10 V/Division, 50 μs/Division
Condition	Power switch ON (IG)

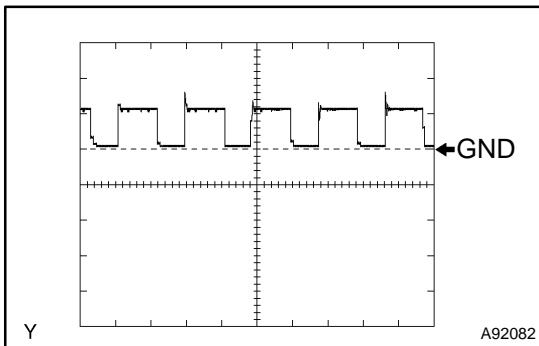

(n) Waveform 14 (boost converter PWM switch signal)

Item	Contents
Terminal	CPWM - GCNV
Equipment Setting	10 V/Division, 50 μs/Division
Condition	Power switch ON (READY), parking brake ON, D position, brake pedal and accelerator pedal depressed

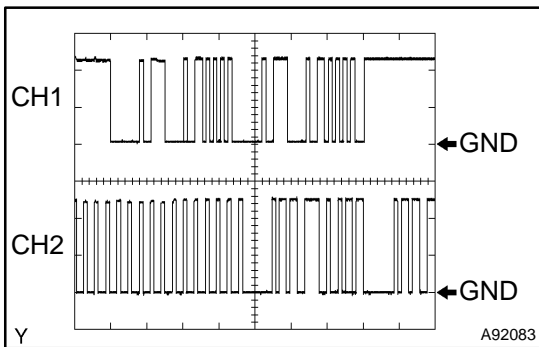

(o) Waveform 15 (immobilizer communication)

Item	Contents
Terminal	CH1: IMO - GND1 CH2: IMI - GND1
Equipment Setting	5 V/Division, 200 ms/Division
Condition	Immobilizer communicating

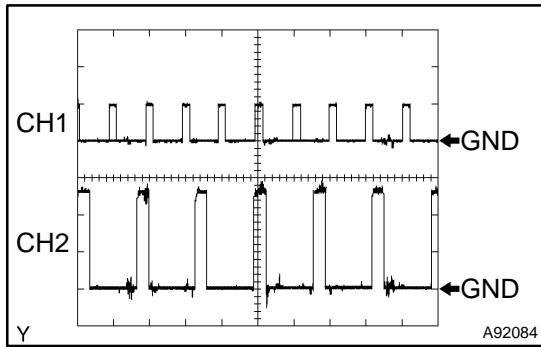

(p) Waveform 16 (P position control signal, P position signal)

Item	Contents
Terminal	CH1: PCON - GND1 CH2: PPOS - GND1
Equipment Setting	5 V/Division, 20 ms/Division
Condition	Power switch ON (IG)

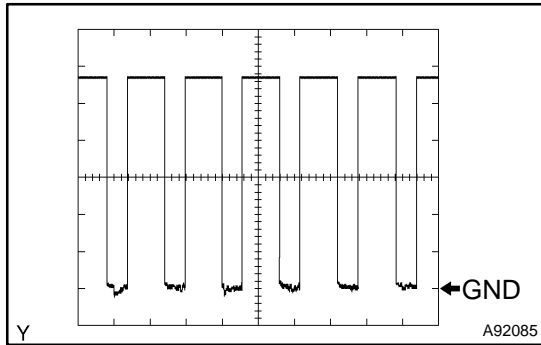

(q) Waveform 17 (READY control signal)

Item	Contents
Terminal	RDY - GND1
Equipment Setting	2 V/Division, 20 ms/Division
Condition	Power switch ON (IG)

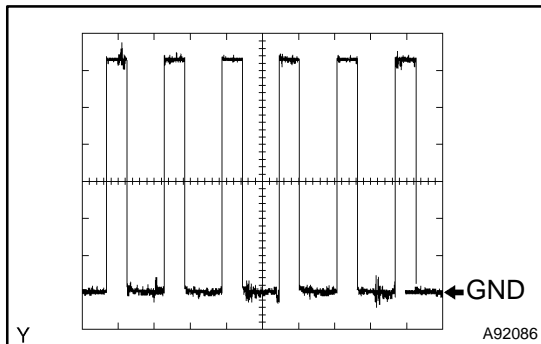

(r) Waveform 18 (READY control signal)

Item	Contents
Terminal	RDY - GND1
Equipment Setting	2V/Division, 20ms/Division
Condition	Power switch ON (READY)

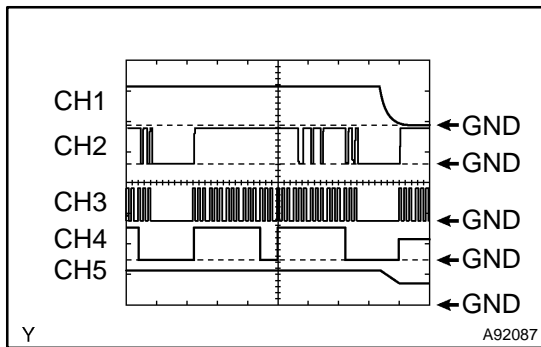

(s) Waveform 19 (A/C communication)

Item	Contents
Terminal	CH1: IGSW - GND1 CH2: ITE - GND1 CH3: CLK - GND1 CH4: ETI - GND1 CH5: STB- GND1
Equipment Setting	10 V/Division, 50 ms/Division
Condition	Power switch ON (IG) and A/C operating